



Siemens PLM Software

What's new in Solid Edge ST7

Re-imagine what's possible

Benefits

- Hundreds of user-requested enhancements
- Faster and more flexible 3D modeling to break through bottlenecks
- Enhance marketing with beautiful photorealistic images
- Complete design projects faster
- Powerful new Apps available
- Enjoy an enhanced user experience

Features

- New 3D sketch tool speeds modeling scenarios
- Specify curves that maintain a fixed length

Summary

Solid Edge® ST7 software from Siemens PLM Software delivers fast and flexible 3D modeling, streamlined design management, powerful new apps and an improved user experience that empower you to re-imagine what's possible, including:

- Faster and more flexible 3D part and assembly modeling, photorealistic renderings and improved 2D drawing production capabilities that enable you to improve product design and get products to market ahead of your competitors



- Expanded visual design management capabilities enable you to complete projects faster and more efficiently
- Wider capabilities for design, manufacturing and collaboration through powerful new and expanded Solid Edge Apps that speed design through manufacturing
- Significant user interface enhancements and easier access to leading design technology speed time-to-value for product development for all types of organizations, from startups to established manufacturers

Accelerate your 3D modeling

Faster and more flexible 3D part and assembly modeling, expanded use of synchronous technology, photorealistic rendering and enhanced 2D drawing production capabilities enable you to design better products and get those products to market ahead of their competition. While there are hundreds of customer

What's new in Solid Edge ST7

Features *continued*

- Create a flattened blank from any 3D model
- Further enhancement of synchronous technology
- The ability to create beautiful photorealistic images
- Faster assembly design and improved tools for patterning components
- Faster drawing production that support international standards
- Expanded visual design management capabilities
- Expanded Solid Edge Apps program
- Monthly subscriptions provide easier access for all
- Expanding academic program and user community
- Faster learning curve with focused learning paths and visual tool tips

enhancements included in Solid Edge ST7, here are the key highlights:

3D Sketch

3D Sketch is available in the part, assembly and sheet metal environments and speeds many modeling scenarios, for example, by rapidly defining 3D paths for sweep operations. You can also use 3D Sketch to model pipes and wires that are bent in more than one plane, and in the assembly environment for the definition of exact paths for piping, wiring and tubing.

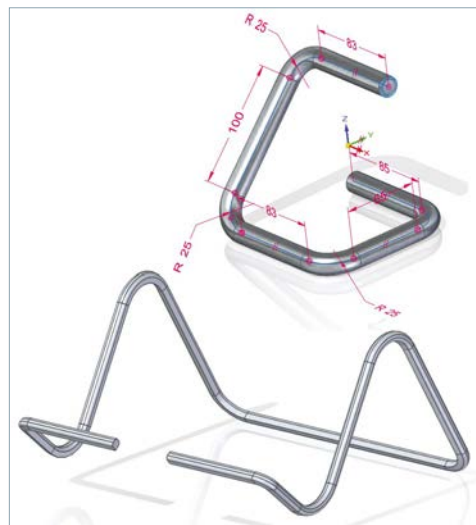

Fixed length curves

You can now design hose type components that have a specific length. The overall length of the curve is maintained when either of the ends is moved. This speeds the placement of hose and cable type components that are purchased in stock lengths.



Enhanced implementation of synchronous technology to speed more design tasks

Solid Edge with synchronous technology supports accelerated design, faster changes, and improved re-use of imported data. Wider implementation of synchronous technology to areas including chamfer recognition, pattern of patterns recognition and control of offset surfaces enable more efficient completion of design tasks and easier use of imported data.

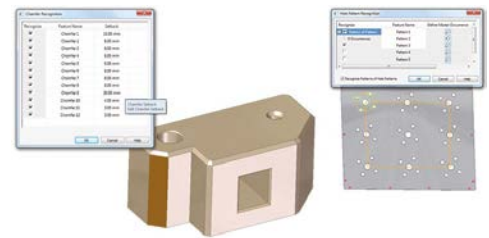

Easy and powerful photorealistic rendering

Create amazing photorealistic images of products designed using Solid Edge with a tightly integrated rendering capability that is included with Solid Edge Classic and Premium. The solution uses KeyShot®, the fastest, easiest way to create beautiful product images and processes concurrently with modeling operations. You can render while you design. Any changes to the model are automatically updated in the rendered image using the "Live Link" capability with no need for you to reassign materials, set up animations again or update any other settings. The resulting images are presented using KeyShot's viewport concurrently with the modeling session.



Intuitive 3D measurement

The 3D measure interface provides you with easier access to comprehensive 3D measurement data and excellent control over the amount of measurement information presented. You can make multiple 3D measurements with a single command and the results are presented onscreen for rapid and accurate communication of measurement data.

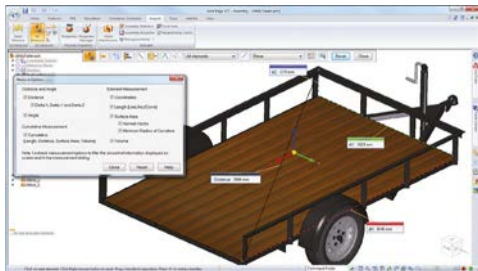

Extensive, standards based hole definition

A more intuitive and visual interface is available for controlling hole definition. The new interface provides wider support for international standards and is available in the part, assembly and sheet metal environments.

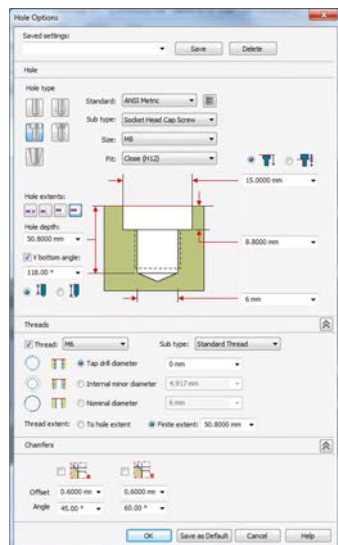

Comprehensive material definition

A more intuitive, visual interface for storing, categorizing and applying material specifications is now available. The interface has enhanced material appearance preview capabilities and you can add your own properties. Material information can be imported from external sources and stored in multiple libraries to support the needs of different departments.

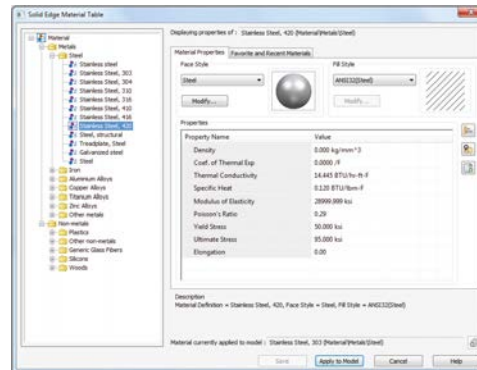

Create blank from a 3D model

Rapid creation of manufacturing information for components that are manufactured using forming, stamping and deep drawn manufacturing processes is now possible using the "Create Blank" command that enables you to create a flattened blank from any 3D model. Formability of different materials is assessed and blank sizes are calculated.

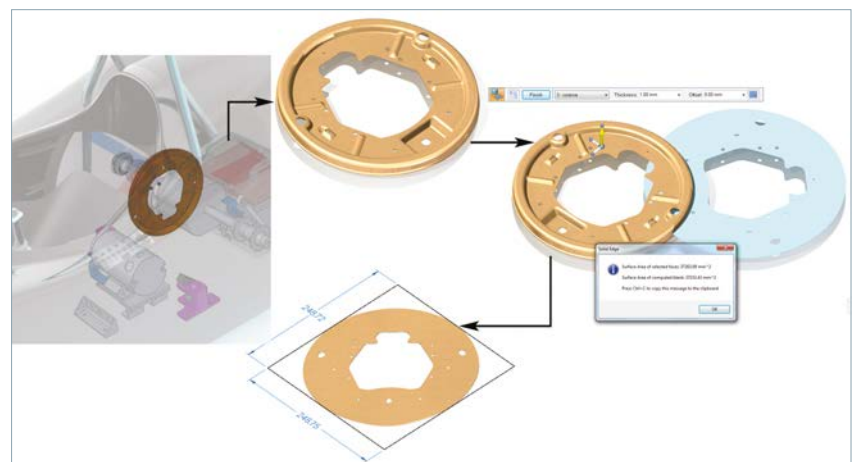

Faster and more flexible assembly design process

Duplicating components in assemblies

The Duplicate Component command speeds assembly design in which components are duplicated in many positions and orientations. Multiple copies of a component can be created based on designated "from" and "to" positions and orientations of existing components.

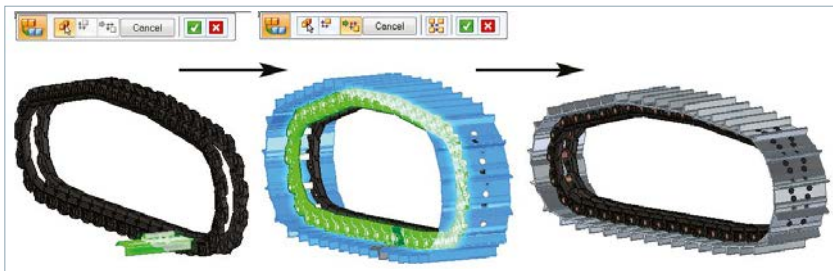

Patterning components along a curve

You can create a pattern of components along a 3D curve, with both position and orientation being controlled by the curve. In this example, a helical curve is used to define the location and orientation of multiple components.

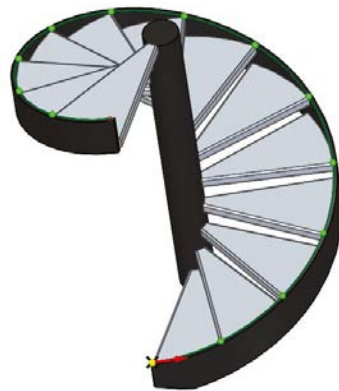

Improved productivity for working with massive assemblies

You now have more control over the extent to which an assembly is recomputed during open and save operations using the Limited Update option. This option speeds response times when working with large assemblies. You also can check for out-of-date components within an

assembly and update and save them using the Component Tracker command.

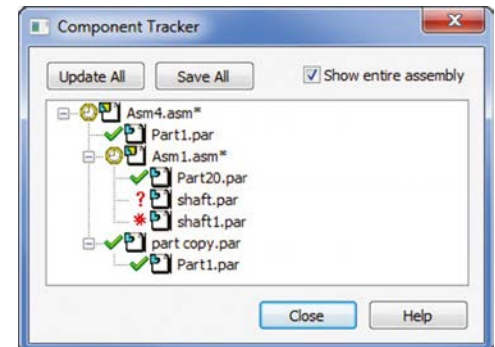

You can insert reference assemblies from a higher level of the assembly into the current level, enabling this data to be used as part of the design process while maintaining correct bill of materials (BOM) generation. You can also designate assemblies as simplified assemblies that are treated as leaf parts and are not automatically expanded. This improves performance when working with large assemblies, while you can still expand these assemblies as needed.

Improved productivity for 2D drawing creation

Placement of coordinate dimensions has been enhanced with easier control of dimension jogging and alignment, improving drafting productivity and making it easier to create clear drawings that meet international standards.

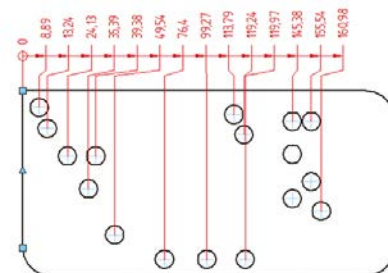

Dynamic display of drawing views during placement has been expanded to include all view types (multiple, principal, auxiliary, section and detail views). A new capability is available that enables you to pull a part

or subassembly out of a higher level assembly and place drawing views of these components, enabling easier detailing of components of an assembly.

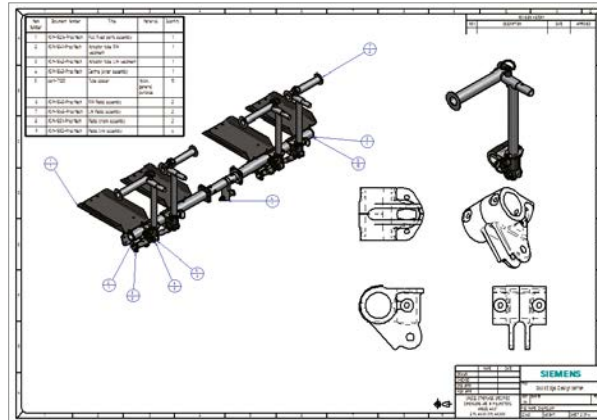

Streamline your design management

Further enhancements to the visual approach to design management provided by Solid Edge SP include the ability to display multiple preview/properties cards simultaneously, and more checkout information being displayed in the web client. Improved support for list-of-value type attributes is also available in which multiple values can be both selected and used for searching. A new workflow site brings user interactions into one location, making it easier to create and work with workflows. You can select individual team members for review and approval tasks when starting a workflow. Automatic links to assemblies and components are now supported as these components are created and revised.

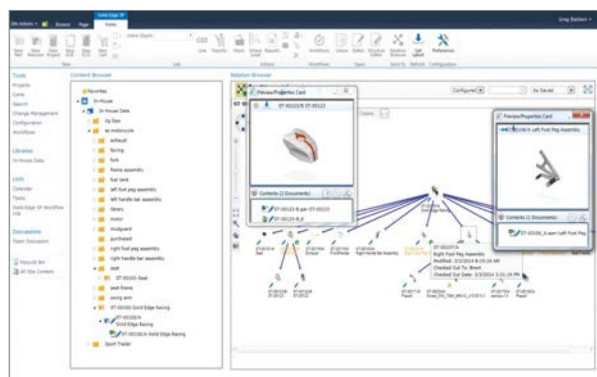

Power up with new apps

An expanded portfolio of both in-house and third-party apps extend Solid Edge beyond core design capabilities and provide integrated solutions for standard and catalog parts libraries, simulation, manufacturing and mobile device support.

Find 3D CAD models quickly and simply with mobile catalog access

The PARTSolutions standard and catalog parts solution from CADENAS can now be used with mobile devices. A new App for Android and iOS devices allows mobile access to structured product catalogs from more than 400 manufacturers.



Faster processing and improved preference handling using Solid Edge Simulation

Solid Edge Simulation, a built-in finite element analysis (FEA) tool that enables design engineers to digitally validate part and assembly designs within the Solid Edge environment, now gives you the ability to specify multiple processor use and the number of processors to be used. A new capability to specify and store global preferences has also been added, enabling you to apply preferences immediately across multiple analyses.



Embedded CAM capabilities with CAMWorks for Solid Edge

The embedded CAMWorks for Solid Edge solution from Geometric has been expanded to include multi-axis milling, wire EDM, and mill-turn capabilities. Support for Solid Edge assemblies allows the NC programmer to see his or her entire setup (including fixtures) while creating tool paths.

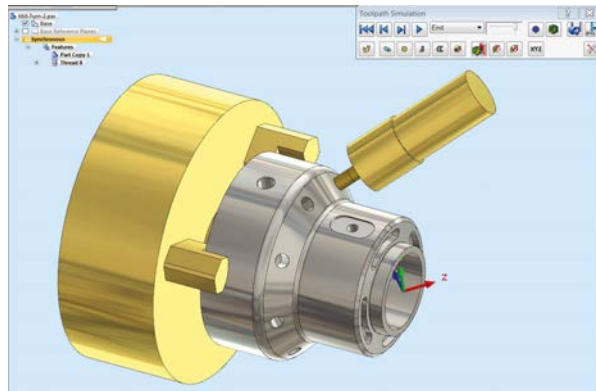

Enhanced Microsoft Surface Pro support

The Microsoft Surface Pro offers full support for Solid Edge design tasks and expanded support for finger gestures is now included. For example, a single finger drag enables a pan operation in 2D and a rotate operation in 3D, and a two finger pinch enables a zoom-in operation.



Enjoy an improved user experience

Unleash your creative potential with easier access to leading design software and the most intuitive Solid Edge user interface to date. New university curricula and school project materials enable more students to build their skills using Solid Edge. A new start page, focused learning paths, and expanded visual tool tips speed learning for all users.

Easier access with monthly subscriptions, a rapidly expanding user community and an enhanced academic program

With the release of Solid Edge ST7, online purchase of monthly subscriptions for Solid Edge will be extended to more than 20 countries, providing a flexible way for you to access class-leading design software. For startups, monthly subscriptions avoid the need for a large initial capital expense. For established manufacturing companies the subscriptions enable you to more easily meet peaks in demand for design resources.



A thriving Solid Edge user community facilitates sharing and learning with a rapidly expanding user website with thousands of interactions, discussions and Q&A entries, more local user meetings and country based Solid Edge University events. The Solid Edge academic program includes new university curricula and expanded school project materials that help lecturers and teachers run improved product design and introduction to engineering classes.

A more intuitive user interface results in a faster learning curve

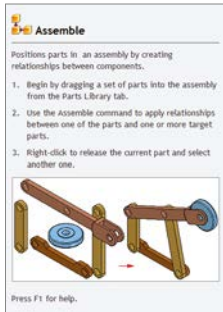

Many user interface enhancements have been made to help ensure a faster, easier learning curve for new users and improve efficiency for experienced users. A visual startup page provides easier access to templates, recent

documents, instructional videos, the online community and standard parts. Learning paths that meet the needs of specific users are easier to access, and an improved 3D orientation

“quick view cube” enables you to quickly understand model orientation and jump to common views.



New tool tips include more text, more graphics and rapid access to instructional videos, and you can control the depth of information presented.

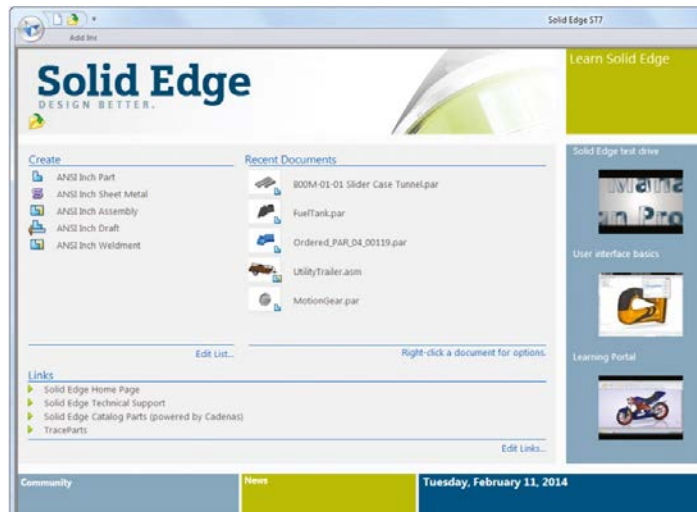

Contact

Siemens Industry Software
 Americas +1 314 264 8287
 Europe +44 (0) 1276 413200
 Asia-Pacific +852 2230 3308

www.siemens.com/plm

© 2014 Siemens Product Lifecycle Management Software Inc. Siemens and the Siemens logo are registered trademarks of Siemens AG. D-Cubed, Femap, Fibersim, Geolus, GO PLM, I-deas, JT, NX, Parasolid, Quality Planning Environment, Solid Edge, Syncrofit, Teamcenter and Tecnomatix are trademarks or registered trademarks of Siemens Product Lifecycle Management Software Inc. or its subsidiaries in the United States and in other countries. All other logos, trademarks, registered trademarks or service marks belong to their respective holders.

Y10 40384 5/14 B